

Preliminary Specifications Subject to Change without Notice

DESCRIPTION

The JW[®]7105B is a current-limited programmable USB switches optimized for applications that require precise current limit, or to provide up to 2.675A of continuous load current during heavy circuits. These devices offer a programmable current-limit threshold between 710mA and 2.675A (Typ.) by an external resistor. The rise and fall times are controlled to minimize current overshoot or undershoot during switches on/off.

The device has fast short-circuited response time for improved overall system robustness. It provides a complete protection solution, such as over-current protection, over-temperature protection and short-circuits protection, as well as controlled rise time and under-voltage lockout function. A 7.5ms deglitch time on the open-drain Flag output prevents false over-current reporting.

JW7105B offers TSOT23-5 package.

Company's Logo is Protected, "JW" and "JOULWATT" are Registered Trademarks of JoulWatt technology Inc.

FEATURES

- Up to 2.675A Maximum Load Current
- Accurate Programmable Current Limit, 710mA-2.675A(Typ.)
- EN active high
- Constant-Current During Over-Current
- Fast Short-Circuit Response Time: 2 μ s (typ.)
- Operating Range: 2.7V - 5.5V
- Built-in Soft-Start with 1ms Typical Rise Time
- Over-Current, and Thermal Protection
- ESD Protection: 2kV HBM, 500V CDM
- Available in TSOT23-5 Package

APPLICATIONS

- Set-Top Boxes
- LCD TVs & Monitors
- Residential Gateways
- Laptops, Desktops, Servers, e-books, Printers, Docking
- Stations, HUBs

TYPICAL APPLICATION

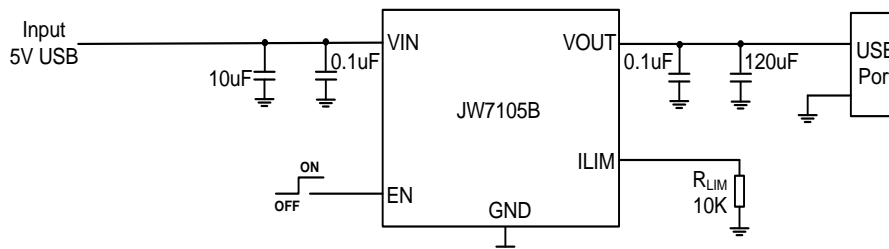

ORDER INFORMATION

DEVICE ¹⁾	PACKAGE	TOP MARKING ²⁾
JW7105BTSOTA#TRPBF	TSOT23-5	JWMF□ YW□□□

Notes:

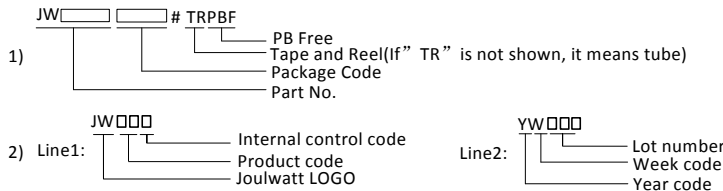

PIN CONFIGURATION

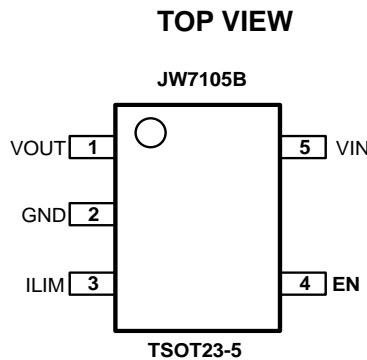

ABSOLUTE MAXIMUM RATING¹⁾

VIN PIN Voltage	-0.3V to 6.5V
VOUT PIN Voltage.....	-0.3V to 6.5V
EN Pin Voltage.....	-0.3V to 6.5V
ILIM Source Current.....	1mA
JunctionTemperature ²⁾	150°C
Lead Temperature	260°C
Storage Temperature	-65°C to +150°C

RECOMMENDED OPERATING CONDITIONS³⁾

VIN PIN Voltage	2.7V to 5.5V
VOUTPIN Voltage.....	0V to (VIN+0.2V)V
EN PIN Voltage.....	0V to 5.5V
High-Level Input Voltage on EN.....	1.4V to VIN
Low-Level Input Voltage on EN.....	0V to 0.5V
Operating Junction Temperature.....	-40°C to 125°C

THERMAL PERFORMANCE⁴⁾ θ_{JA} θ_{JC}

TSOT23-5.....220....130°C/W

Note:

- 1) Exceeding these ratings may damage the device. These stress ratings do not imply function operation of the device at any other conditions beyond those indicated under RECOMMENDED OPERATING CONDITIONS.
- 2) The JW7105B includes thermal protection that is intended to protect the device in overload conditions. Continuous operation over the specified absolute maximum operating junction temperature may damage the device.
- 3) The device is not guaranteed to function outside of its operating conditions.
- 4) Measured on JESD51-7, 4-layer PCB

ELECTRICAL CHARACTERISTICS

<i>TA = +25°C, VIN = 2.7V to 5.5V, VEN = 0V or VEN = VIN, unless otherwise stated.</i>						
Item	Symbol	Condition ⁵⁾	Min.	Typ.	Max.	Units
<i>Supply</i>						
Input UVLO	V _{UVLO}	VIN Rising		2.3	2.65	V
Input UVLO Hysteresis	ΔV _{UVLO}	VIN Decreasing		150		mV
Input Shutdown Current	I _{SHDN}	V _{IN} = 5.5V, Disabled, V _{OUT} = Open		0.1	1	uA
Input Quiescent Current	I _Q	V _{IN} = 5.5V, Enabled, V _{OUT} = Open, R _{LIM} = 20kΩ		130	180	uA
<i>Power Switch</i>						
Switch On-Resistance ⁵⁾	R _{DS(ON)}	T _J = +25°C, V _{IN} = 5.0V		25	30	mΩ
Output Turn-On Rise Time	t _r	V _{IN} = 5.5V, C _L = 1μF, R _{LOAD} = 100Ω. See Figure 1.		1.1	1.5	ms
		V _{IN} = 2.7V, C _L = 1μF, R _{LOAD} = 100Ω.		0.7	1	
Output Turn-Off Fall Time	t _f	V _{IN} = 5.5V, C _L = 1μF, R _{LOAD} = 100Ω. See Figure 1.	0.1		0.5	ms
		V _{IN} = 2.7V, C _L = 1μF, R _{LOAD} = 100Ω.	0.1		0.5	
<i>Current Limit</i>						
Current-Limit Threshold (maximum DC output current), V _{OUT} = V _{IN} - 0.5V	I _{LIMIT}	R _{LIM} = 10kΩ	2.45	2.675	2.9	A
		R _{LIM} = 50kΩ		0.71		
Short-Circuit Current Limit, V _{OUT} Connected to GND	I _{SHORT}	R _{LIM} = 10kΩ	2.4	2.5	2.6	A
		R _{LIM} = 49.9kΩ		0.58		
Short-Circuit Response Time ⁷⁾	t _{SHORT}	V _{OUT} = 0V to I _{OUT} = I _{LIMIT} (V _{OUT} shorted to ground). See Figure 2.		2		μs
<i>Enable Pin</i>						
EN Input Leakage Current	I _{LEAK-EN}	V _{IN} = 5V, V _{EN} = 0V and 6V	-0.5		0.5	uA
Turn-On Time	t _{ON}	C _L = 1μF, R _L = 100Ω. See Figure 1.			3	ms
Turn-Off Time	t _{OFF}	C _L = 1μF, R _L = 100Ω. See Figure 1.			1	ms
EN High Level Voltage	V _{ENH}		1.4			V
EN Low Level Voltage	V _{ENL}				1	V
<i>Output Discharge</i>						
Discharge Resistance ⁶⁾	R _{DIS}	V _{IN} = 5V, Disabled, I _{OUT} = 1mA		600		Ω
<i>Thermal Shutdown</i>						
Thermal Shutdown Threshold ⁷⁾	T _{SHDN}	Enabled, R _{LOAD} = 1kΩ		160		°C
Thermal Shutdown Threshold under Current Limit ⁷⁾	T _{SHDN_OCP}	Enabled, R _{LOAD} = 1kΩ		140		°C

Thermal Shutdown Hysteresis ⁷⁾	T _{HYS}			20		°C
---	------------------	--	--	----	--	----

Note:

- 5) Pulse-testing techniques maintain junction temperature close to ambient temperature; thermal effects must be taken into account separately.
- 6) The discharge function is active when the device is disabled (when enable is de-asserted or during power-up power-down when VIN < VUVLO). The discharge function offers a resistive discharge path for the external storage capacitor for limited time.
- 7) Guaranteed by design

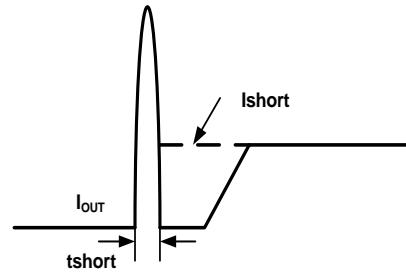
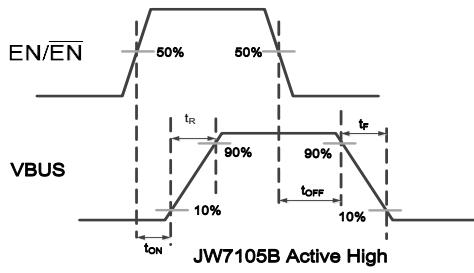

Figure 1 Voltage Waveforms

Figure 2 Response Time to Short Circuit Waveform

PIN DESCRIPTION

Pin TSOT23-5	Name	Description
1	VOUT	Output.
2	GND	Ground.
3	ILIM	Use external resistor to set current-limit threshold; Recommended $10k\Omega \leq R_{LIM} \leq 49.9k\Omega$.
4	EN	Enable input. JW7105B: logic high turns on power switch.
5	VIN	Input, connect a 0.1 μ F or greater ceramic capacitor from VIN to GND as close to IC as possible.

BLOCK DIAGRAM

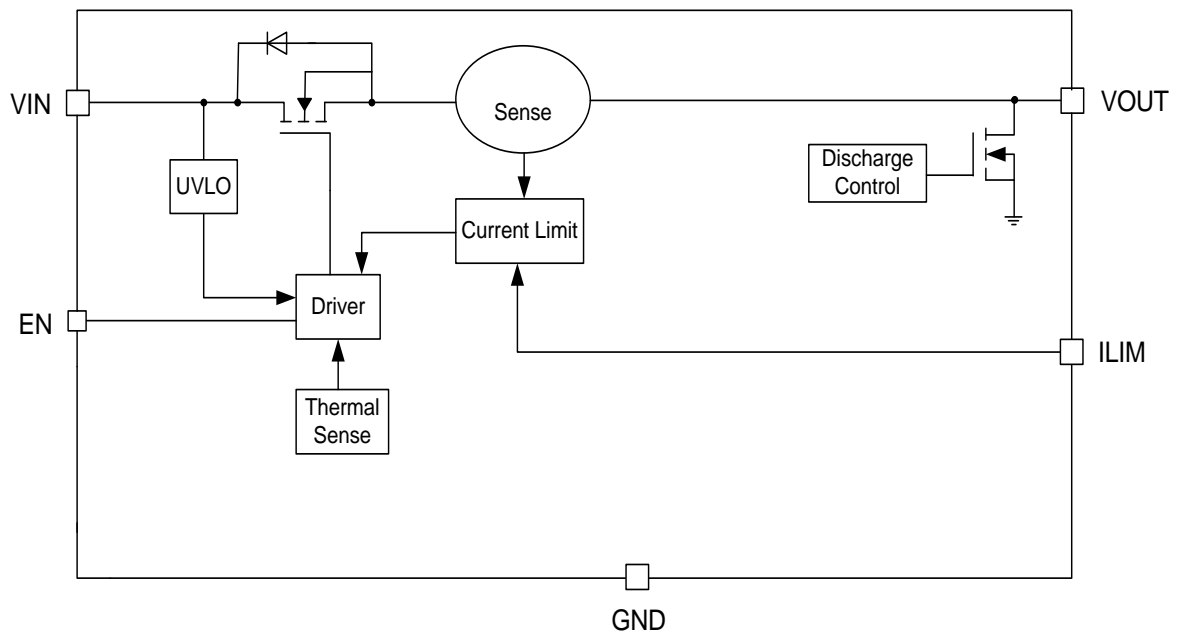

FUNCTIONAL DESCRIPTION

The JW7105B integrates high-side MOSFET optimized for Universal Serial Bus (USB) that requires protection functions. The MOSFET is driven with controlled gate voltage and slew-rate, which makes this USB device ideal for hot-swap or hot-plug applications.

Discharge Function

When enable is de-asserted, or when the input voltage is under UVLO level, the discharge function is active. The output capacitor is discharged through an internal NMOS in series with a 100Ω resistor. The discharge time is dependent on the RC time constant of the resistance and output capacitance.

Power Supply Considerations

A 10μF X7R or X5R ceramic capacitor between VIN and GND, close to the device, is highly recommended. This limits the input voltage drop during line transients. Placing a high-value electrolytic capacitor on the input (10μF minimum) and output pin (120μF) is recommended when the output load is heavy.

Additionally, bypassing the device output with a 0.1μF to 4.7μF ceramic capacitor improves the immunity of the device to short-circuit condition.

This capacitor also prevents output from going negative during turn-off due to parasitic inductance. If the negative kick is less than -1V, a schottky diode in parallel with VOUT pin is recommended. Otherwise, the device may go malfunction.

Generic Hot-Plug Applications

In many applications it is common to remove modules or PC boards while the main unit is still operating. These are considered hot-plug applications. Such implementations require the control of current surges. The most effective way to control the current surge is to limit and slowly

ramp the current and voltage being applied to the card, similar to the Soft Start in which a power supply normally turns on. Due to the controlled rise and fall times of the JW7105B, these devices can be used to provide a softer start-up to devices being hot-plugged into a powered system.

The UVLO feature of the JW7105B also ensures that the switch is off after the card has been removed, and that the switch is off during the next insertion.

Generic Hot-Plug Applications

By placing the JW7105B between the VCC input and the rest of the circuitry, the input power reaches these devices first after insertion. The typical rise time of the switch is approximately 1ms, providing a slow voltage ramp at the output of the device. This implementation controls system surge current and provides a hot-plugging mechanism for any device.

Under-Voltage Lockout (UVLO)

Whenever the input voltage falls below UVLO threshold (~2.5V), the power switch is turned off. This facilitates the design of hot-insertion systems where it is not possible to turn off the power switch before input power is removed.

Over-Current and Short-Circuit Protection

An internal sensing FET is employed to sense over-current conditions. Unlike current-sense resistors, sensing FETs do not increase the series resistance of the current path. When an over current condition is detected, JW7105B maintains a constant output current and reduces the output voltage accordingly. Complete shutdown occurs only if the fault stays long enough to activate over-temperature

protection.

Current Limit Setting

The current limit can be programmed by an external resistor. The current limit is proportional to the current sourced out of ILIM pin.

The recommended 1% resistor range for R_{LIM} is 10kΩ ≤RLIM≤49.9kΩ. The traces routing the R_{LIM} resistor to the JW7105B should be as short as possible to reduce parasitic effects on the current-limit accuracy.

To design a maximum current limit, find the intersection of R_{LIM} and the maximum desired load current. The typical current limit can be calculated by

$$I_{lim} = \frac{0.1}{R_{Lim}} \times 245.6 + 0.219$$

And also R_{LIM} can be calculated by

$$R_{lim} = \frac{24.56}{I_{Lim} - 0.219} (k\Omega)$$

Over-Temperature Protection

Thermal protection prevents the IC from damage when the die temperature exceeds safe margins. This mainly occurs when heavy-overload or short-circuit faults occurs. The JW7105B implements a thermal sensing circuit to monitor the operating junction temperature. Once the die temperature rises to approximately +160°C (+140°C in case the part is under current limit), the thermal protection feature activates as follows: The internal thermal sense circuitry turns the power switch off, thus preventing the power switch from damage. Once the junction temperature drops to 140°C, the MOSFET restart to work.

PACKAGE OUTLINE

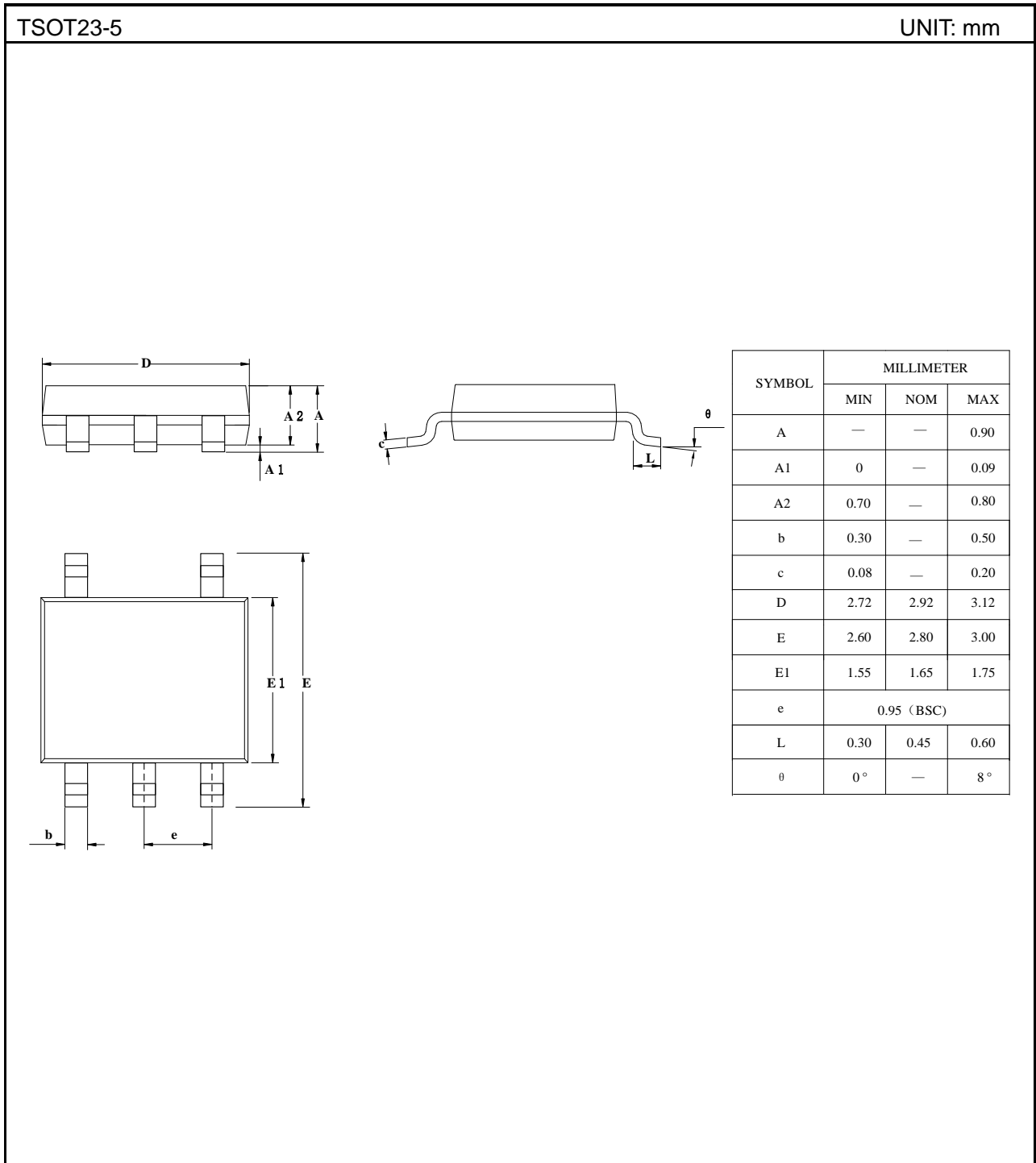

IMPORTANT NOTICE

- Joulwatt Technology Inc. reserves the right to make modifications, enhancements, improvements, corrections or other changes without further notice to this document and any product described herein.
- Any unauthorized redistribution or copy of this document for any purpose is strictly forbidden.
- Joulwatt Technology Inc. does not warrant or accept any liability whatsoever in respect of any products purchased through unauthorized sales channel.

Copyright © 2018 JW7105B Incorporated.

All rights are reserved by Joulwatt Technology Inc.